

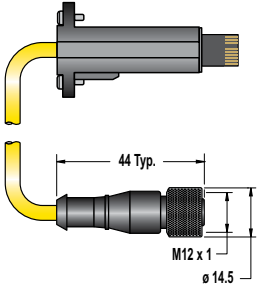

8-Pin Threaded M12/Euro-Style QD to RD Cordsets

Cable: Euro: PVC jacket, PVC connector body, nickel-plated brass coupling nut
 RD: Nylon (polyamide)/PUR (polyurethane) RD connector
Conductors: 22 AWG, gold-plated contacts
Voltage/Current Rating: 60V ac/75V dc, 2.0 A
Temperature: 0° to +55° C **Environmental Rating:** IP67

Style	Length	Model*	Cable Diameter	Dimensions (mm)	Pinout	Used With
RD/ Female Straight	0.31 m	DELPEF-81D	6.00 mm		 RD  Female 1 = Brown 5 = Black 2 = Or/Bk 6 = Blue 3 = Orange 7 = Gn/Ye 4 = White 8 = Violet	• EZ-SCREEN LP (Cascade) w/RD (14 & 25 mm); requires QDE2R4-8...D cordset or connection of E-stop or other hard/relay contact; for connection to DEE2R-8..D or to EZ-SCREEN LP w/8-pin QD
	0.91 m	DELPEF-83D				
	2.44 m	DELPEF-88D				
	4.57 m	DELPEF-815D				

- Accessories
- Brackets
- Cordsets
- Retroreflectors
- Miscellaneous
- Reference

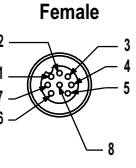
RD to Flying Lead Cordsets

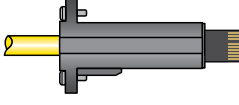
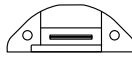

Cable: PVC jacket, nylon (polyamide)/PUR (polyurethane) RD connector
Conductors: 22 AWG, gold-plated contacts
Voltage/Current Rating: 60V ac/75V dc, 2.0 A
Temperature: 0° to +55° C **Environmental Rating:** IP67

Style	Length	Model*		Cable Diameter	Dimensions (mm)	Pinout	Used With
		8 wire	4 wire†				
RD	4.57 m	RDLP-815D	RDPL6G-415D	6.00 mm		 RD	• EZ-SCREEN LP w/RD (14 & 25 mm Resolution)
	7.62 m	RDLP-825D	RDPL6G-425D				
	15.2 m	RDLP-850D	RDPL6G-450D				
	22.9 m	RDLP-875D	—				
	30.5 m	RDLP-8100D	—				

† For connection of E-Stop or other hard/relay contacts. See EZ-SCREEN installation manual p/n 140044 for more information.

RD to RD Cordsets

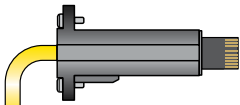
Cable: PVC jacket, nylon (polyamide)/PUR (polyurethane) RD connector
Conductors: 22 AWG, gold-plated contacts
Voltage/Current Rating: 60V ac/75V dc, 2.0 A
Temperature: 0° to +55° C **Environmental Rating:** IP67

Style	Length	Model*	Cable Diameter	Dimensions (mm)	Pinout	Used With
RD/RD	0.05 m	DELP-110E	6.00 mm		 RD	• EZ-SCREEN LP w/RD Cascading (14 & 25 mm Resolution)
	0.30 m	DELP-111E				
	0.91 m	DELP-113E				
	2.44 m	DELP-118E				
	4.57 m	DELP-1115E				
	7.62 m	DELP-1125E				
	15.2 m	DELP-1150E				
	22.9 m	DELP-1175E				
	30.5 m	DELP-11100E				

* Standard cordsets are yellow PVC with black overmold. For black PVC cable and overmold, add suffix **B** to model number (example, **DELP-110EB**).